

HP Latex 800 Printer series Printer assembly instructions

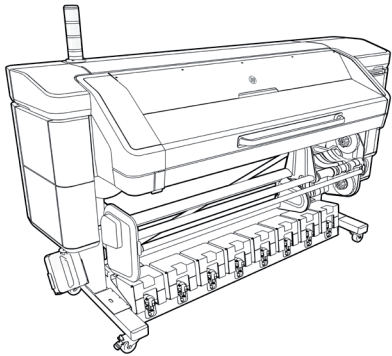

2 people are required to perform certain tasks.



Time required for assembly of the printer is approximately 210 minutes.

Note: Depending on your LAN installation, a web proxy server name and port may be required to complete the installation of this printer. Contact your IT manager to get connectivity settings.

Edition 2

© Copyright 2021 HP Development Company
L.P. Large Format Division
Cami de Can Graells 1-21
08174 - Sant Cugat del Valles
Barcelona - Spain

All rights reserved



Please read these instructions carefully. These assembly instructions explain how to assemble the printer. Because spare screws are supplied, some screws will remain unused after assembly of the printer.

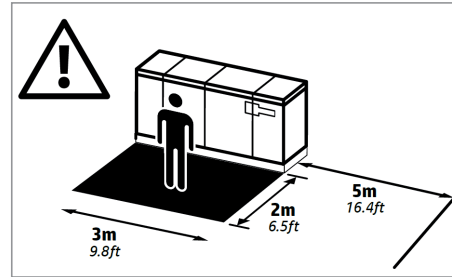

The space required for assembly is:
2 m x 3 m (6.5 ft x 9.8 ft) at the front, and 5 m (16.4 ft) at the side.

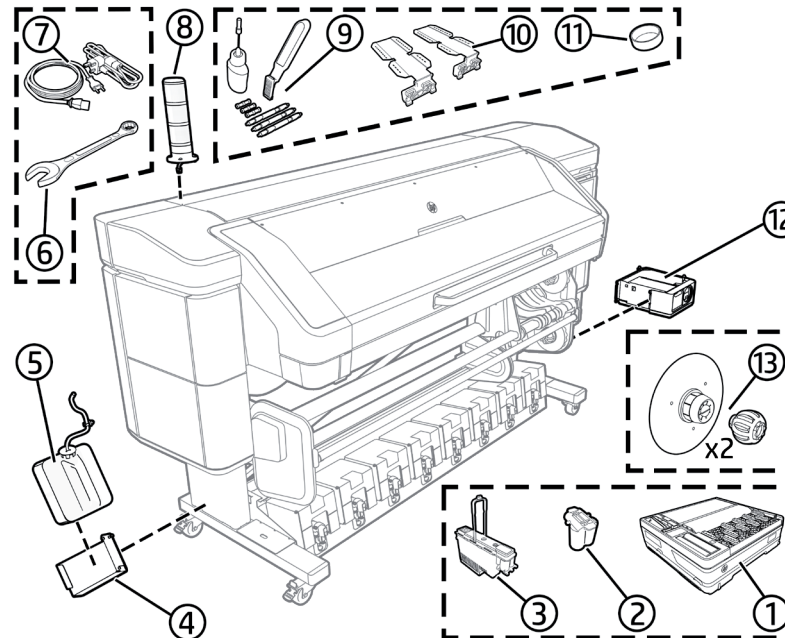

Box Contents

1. Maintenance cartridge
2. Purgers
3. Printheads
4. Condensation collector support
5. Condensation collector
6. Spanner size 17
7. EE cables
8. Beacon accessory
9. User maintenance
10. Edge holders
11. Condensation collector cap
12. White ink kit (only for HP Latex 800W)
13. 2-inch hub

LAN cable, roll of substrate, and cartridges are not included.

Tools required:

Electrical nut driver size 17 / Cutter / Forklift / Flat screwdriver

Note: Assembly can be done with manual tools only, but installation will take longer.

Note: The printer body cannot be disassembled from the legs. Correct printer functionality cannot be assured.

Remove the packaging

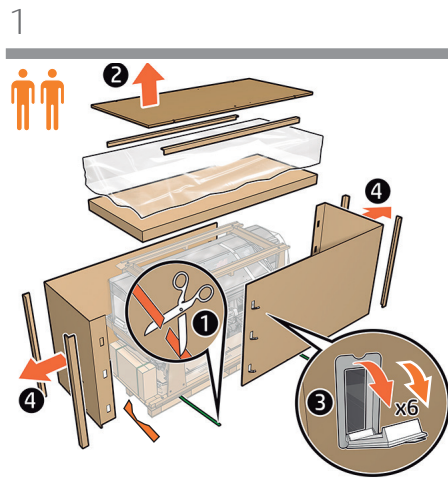

Close the box lids, remove the plastic covers and remove the box cover. Remove the box by lifting it upwards.

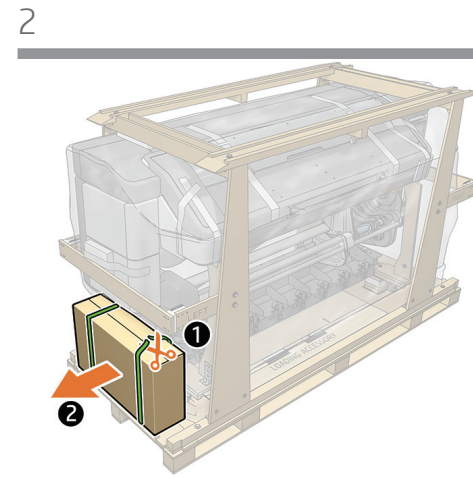

Remove all the boxes and other items from the printer.

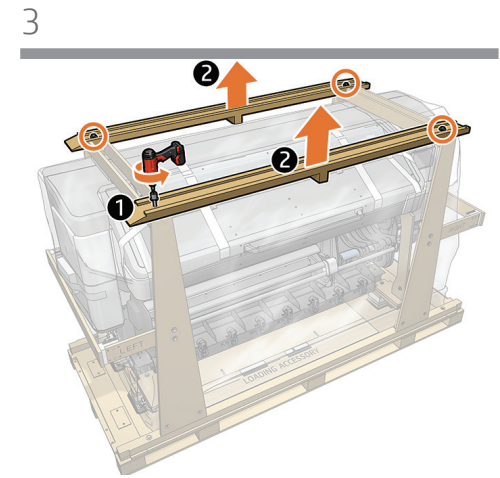

Remove 2 screws from each support using the size 17 electrical nut driver or spanner, then remove the 2 supports.

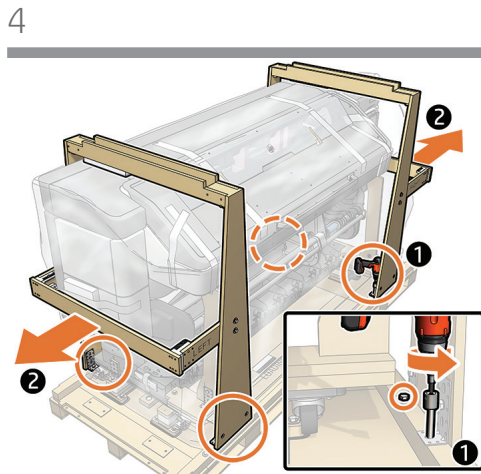

Remove the wooden supports.
Important: Keep the screws for the next step.

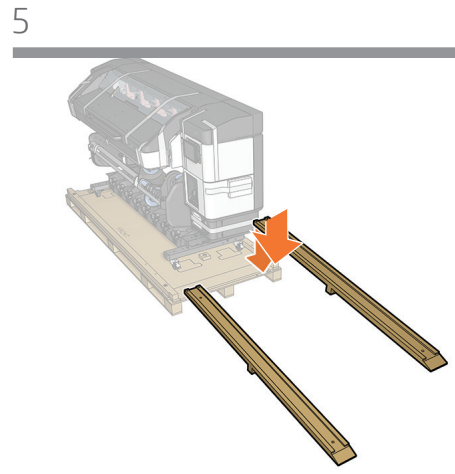

Place the ramps in position on the pallet.

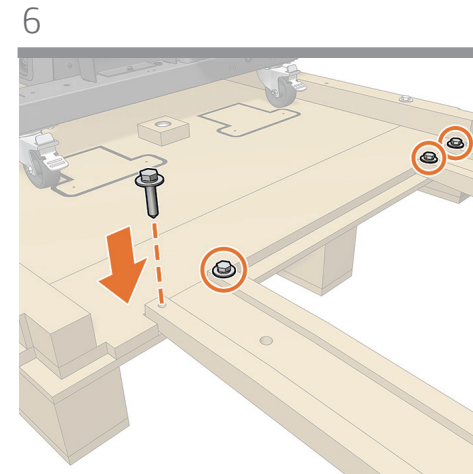

Fix the ramps to the pallet with the screws removed previously; 2 screws each ramp.
Important: The ramps must be fixed correctly before you move the printer.

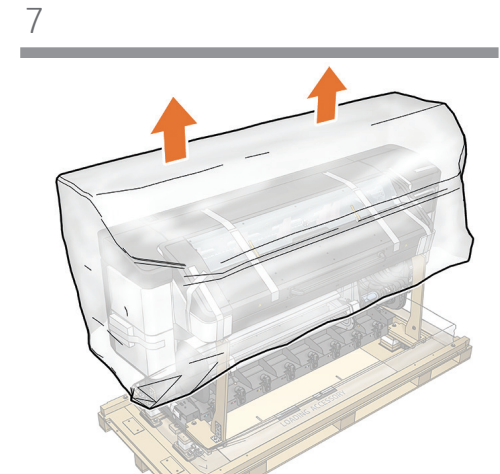

Remove the plastic bag.

Take the printer off the pallet

8

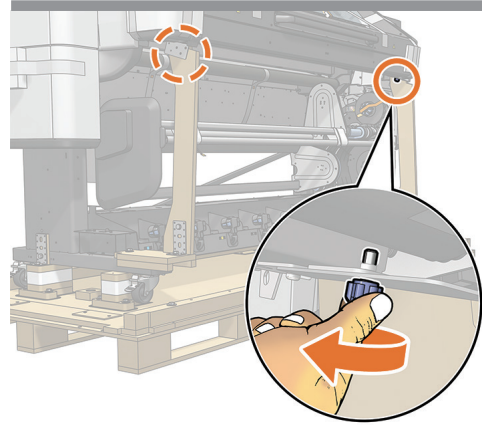

Remove the screws from the curing module crate's vertical supports.

9

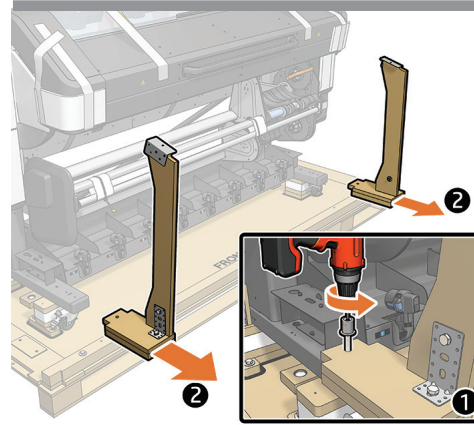

Remove the vertical supports from the front of the crate.

10

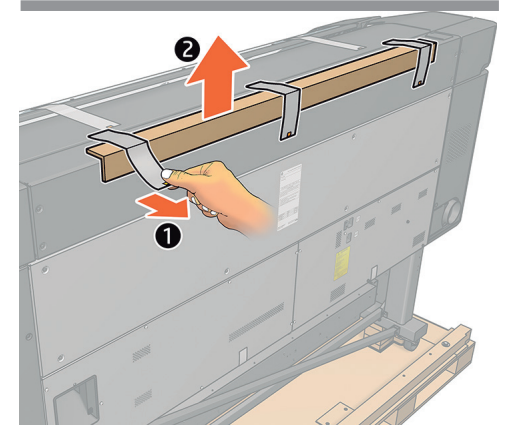

Remove the cardboard protector from the rear top edge.

11

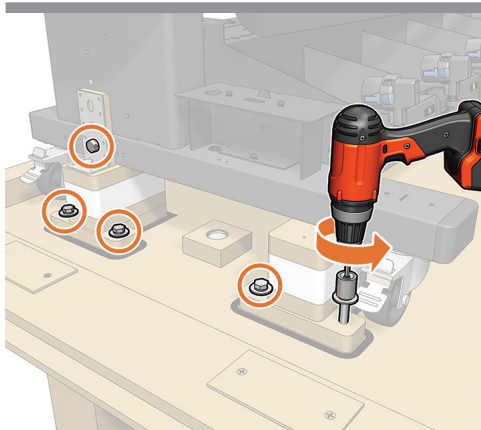

Remove 5 screws from the side of the printer.

12

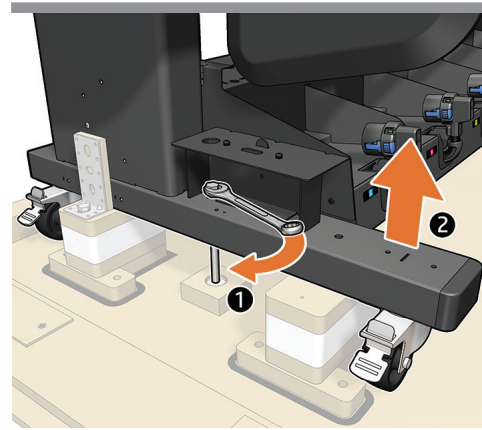

Take the screw, and at the left-hand side, use it to raise the printer by tightening the screw with the wrench.
Caution: Do not lift the printer manually.

13

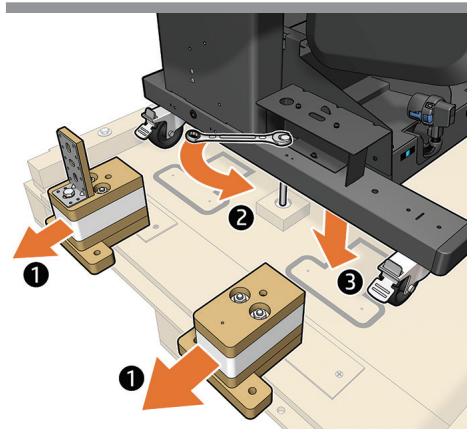

Remove the foam and lower the printer.
Repeat the process at the other side of the printer.

14

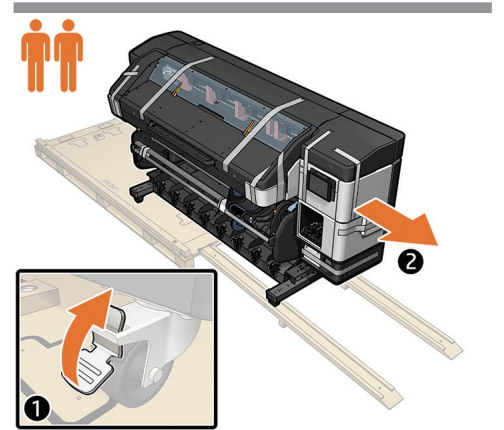

Roll the printer out of the pallet and down the ramps.
Important: 2 people are required.

Install the beacon

15

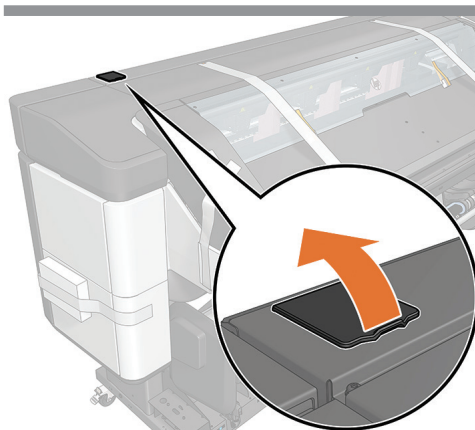

If your printer has a beacon, open the beacon cover at the left-hand side..

16

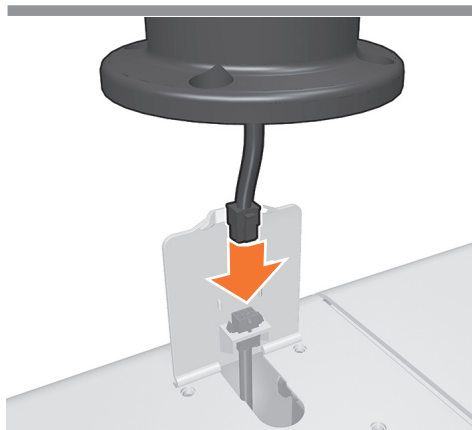

Connect the cable.

17

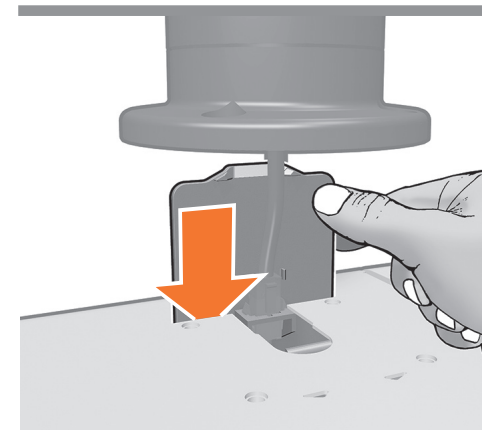

Lower the cover.

18

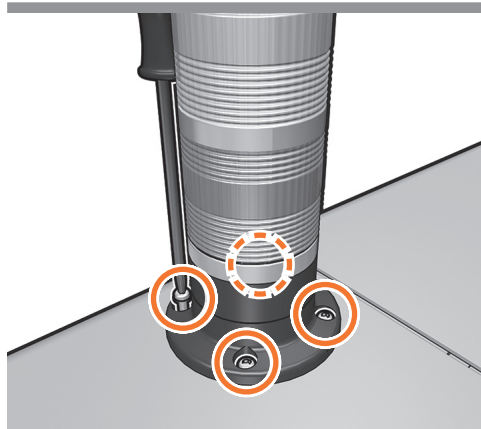

Tighten the 4 (T-25) screws.

Unpack more components

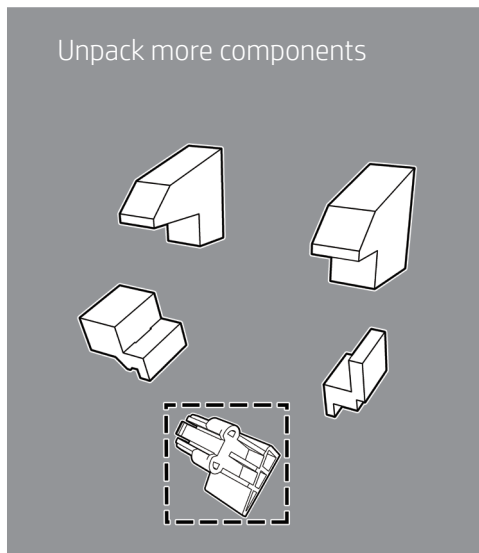

19

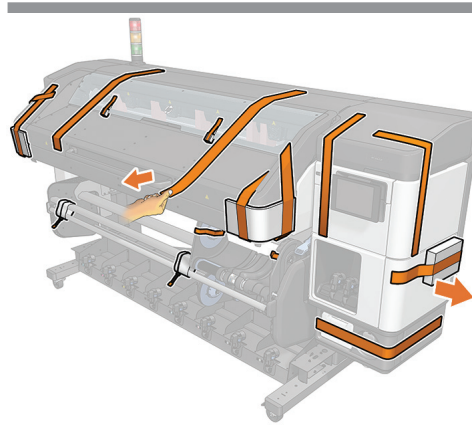

Remove all the tapes from the outside of the printer.

20

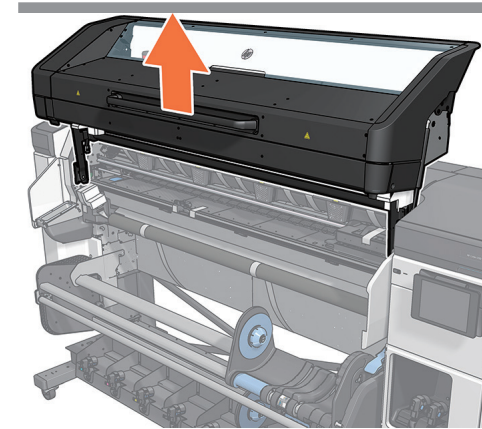

Raise the curing module

21

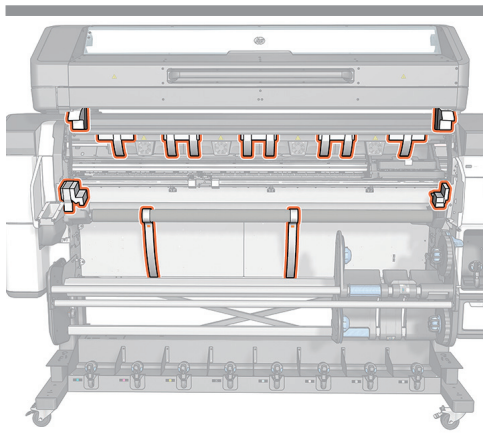

Remove all the tapes.

22

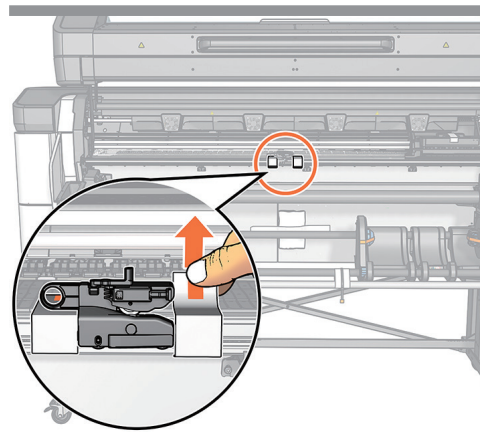

Remove the tape from the cutter.

Caution: Be careful when removing the tape from the cutter, it stuck to the platen and also to the plastic part of the cutter guide. Do not remove the plastic guide when peeling the tape off the platen.

23

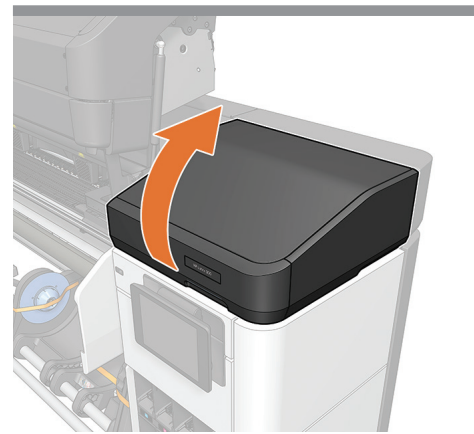

Open the carriage cover.

24

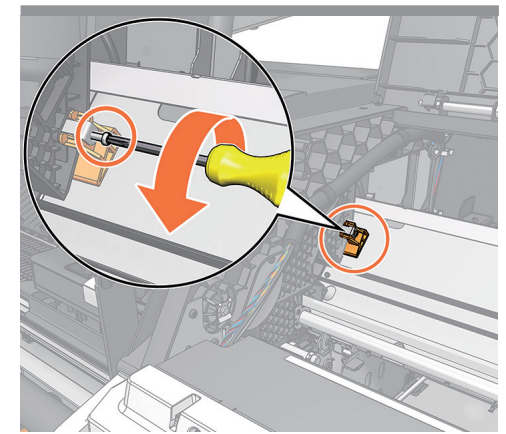

Remove the screw from the orange pin

25

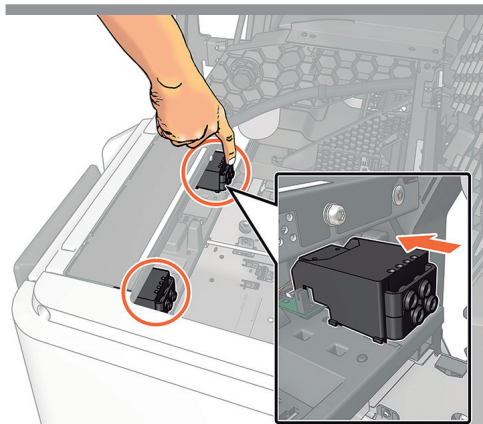

Check that the primer modules are firmly in place.

26

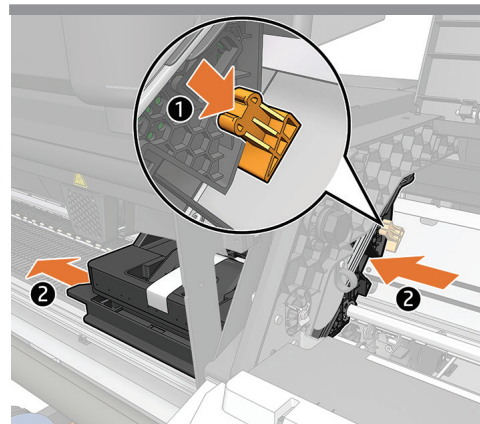

Slide the carriage to the left and remove the orange pin.

27

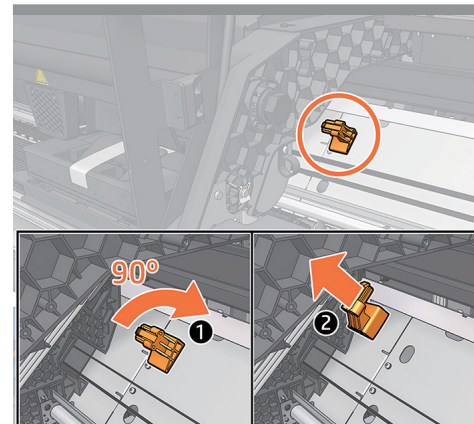

Rotate the orange piece clockwise and take it out.

Important: Keep it for future transportation

28

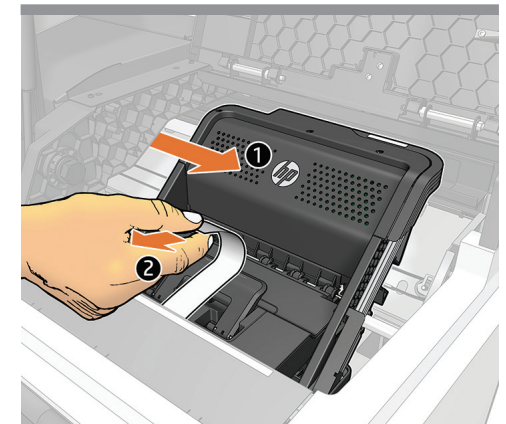

Slide the carriage to the right and remove the strap.

29



Close the carriage cover.

30



Lower down the curing module.

31

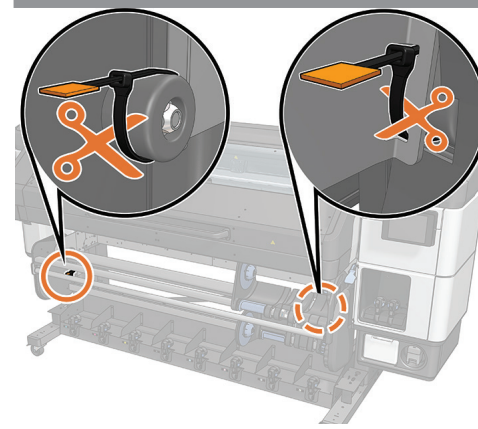

Remove the tie from media input and media output sides.

32

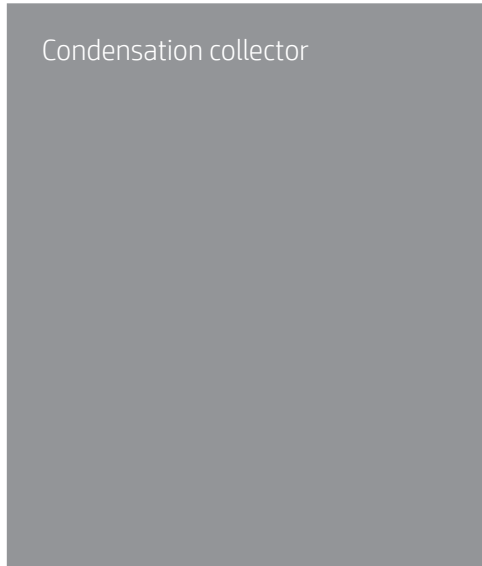

Condensation collector

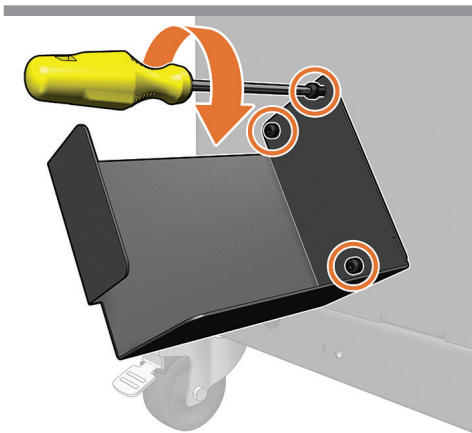

Take the condensation collector holder from the box and fix it to the bottom of the left leg with 3 screws.

33

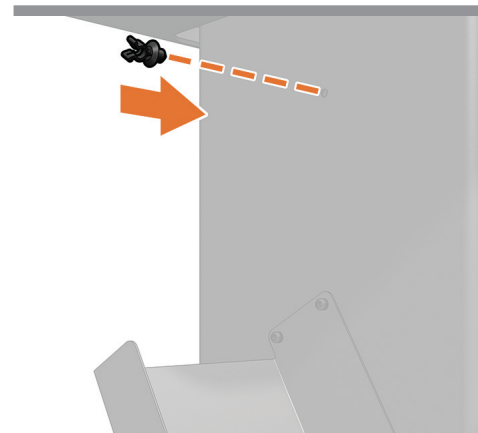

Place the tube holder on top of the bottle holder.

34

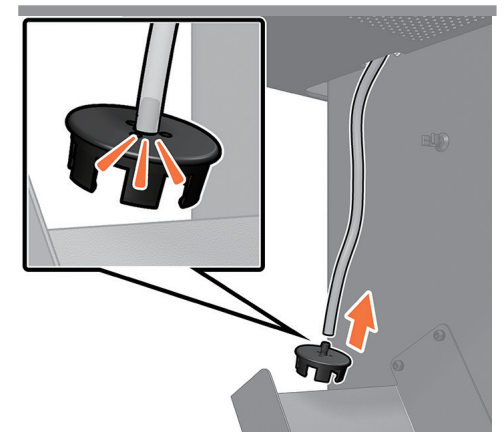

Connect the condensation collector cap to the tube.

35

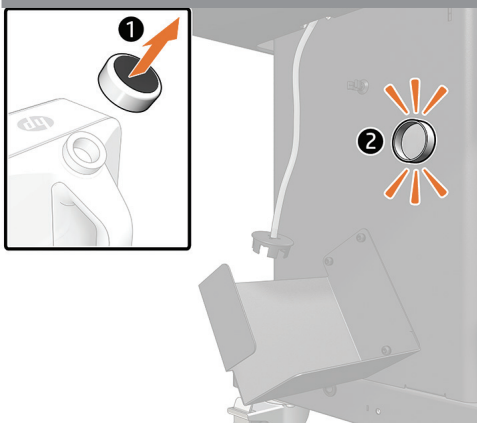

Keep the cap and place it onto the leg (it is magnetic).

36

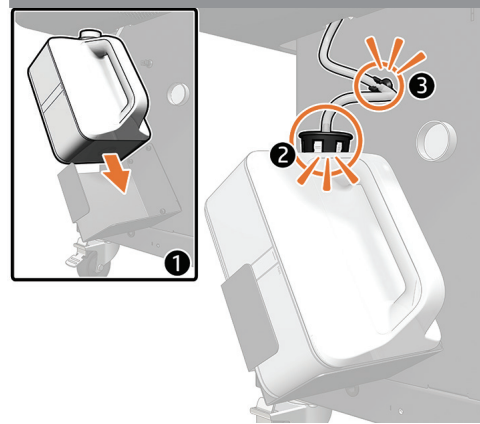

Place the condensation collector into the holder and connect the tube.

Move and setup the printer

37

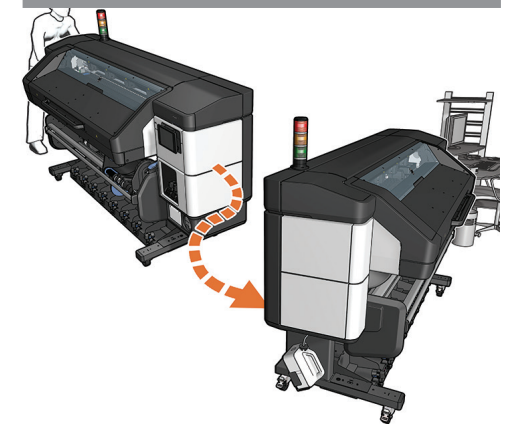

Move the printer to its final location.

38

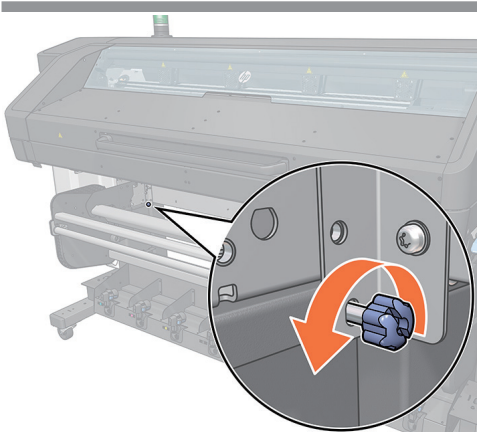

At the left-hand side of the printer, at the back, remove the blue screw.

39

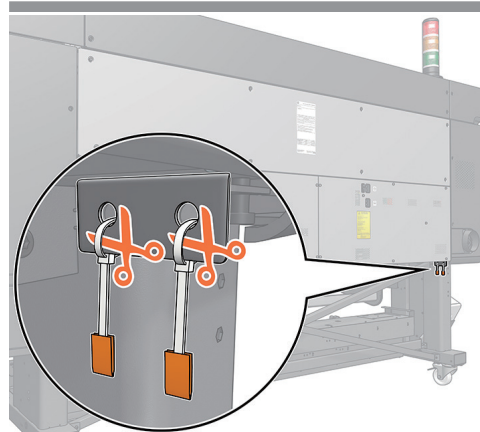

At the left-hand side of the printer, at the rear, remove the stand locker

Install the ink cartridge bay

40

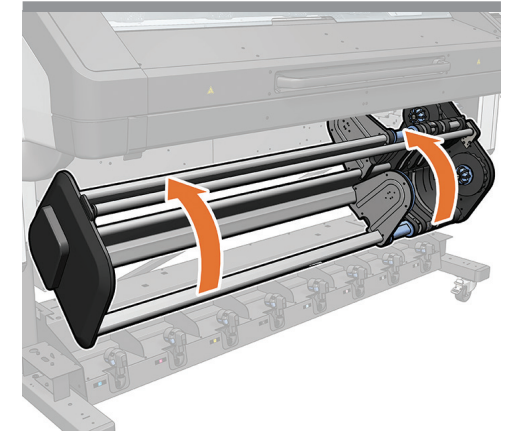

Raise the input-output module to its top position.

41

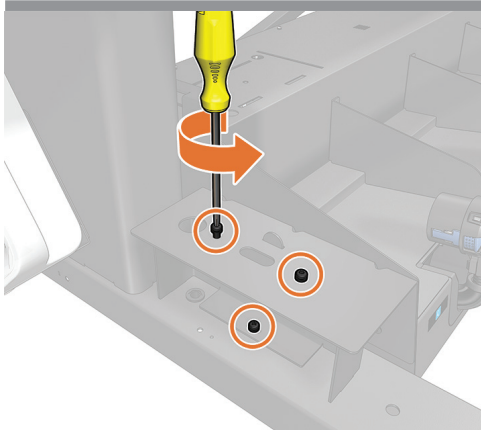

Make sure that no substrate is loaded. Take out the screws at both sides of the printer and remove the lifting pieces at the rear of the printer. Keep the 3 screws from each piece.

42

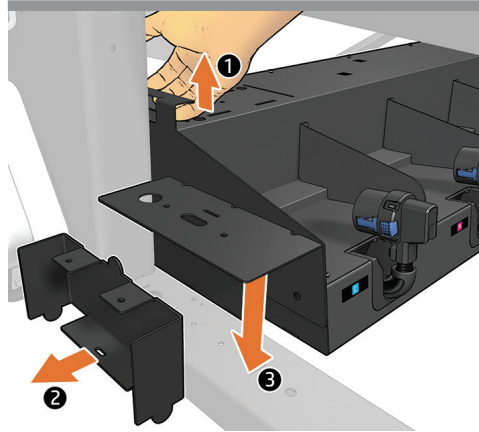

Lift the ink tank bay with the handle. Remove the lifting piece. Lower the ink tank back into place.

43

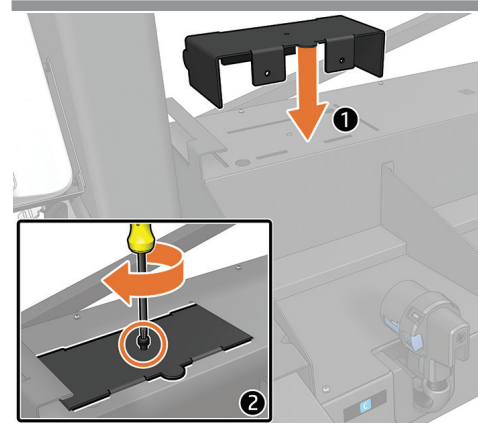

Put the lifting piece into its storing position (for future transportation) and fix it there with one of the screws removed previously.

44

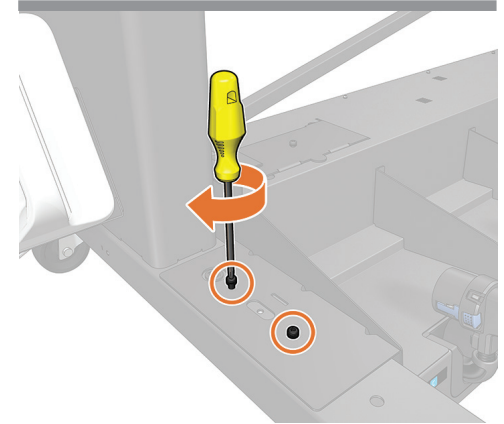

Fix the ink tank bay back into place with the 2 remaining screws removed previously. Repeat the process at the right-hand side of the printer.

Setup the printer

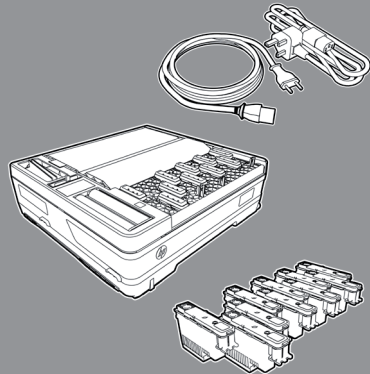

45

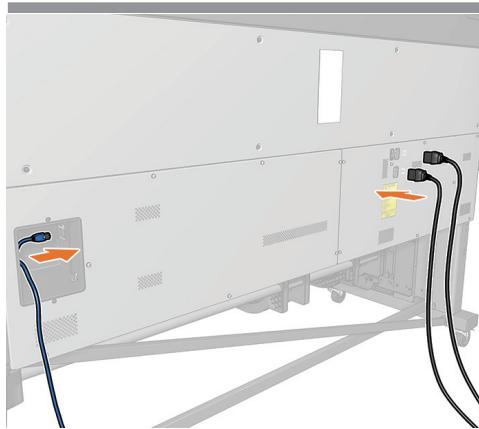

Connect LAN and power cord cables: printer and curing.
Important: Ensure that the building's electrical system meets the printer's electrical requirements. Please refer to the Site Preparation Guide for more information.

46

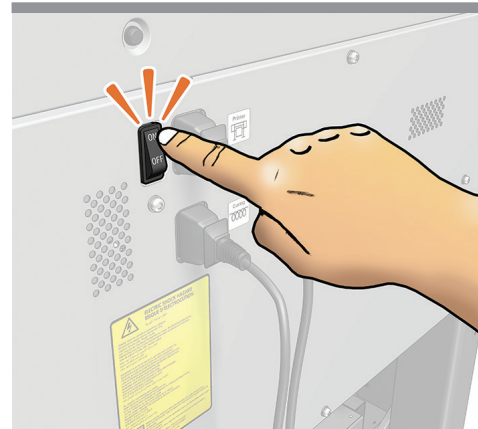

Switch on the printer at the rear.
Note: Make sure that the condensate collector is properly connected.

47

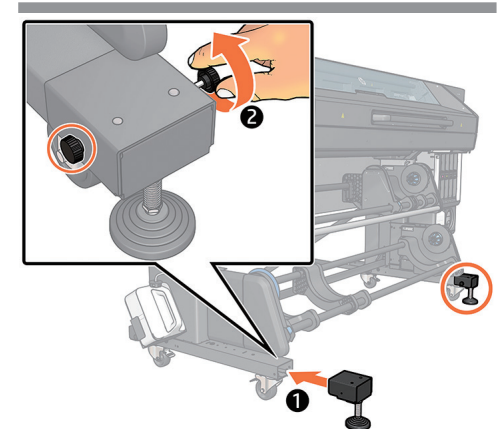

Install the 2 extension feet onto the front of the legs and fix with 2 screws each foot.

48

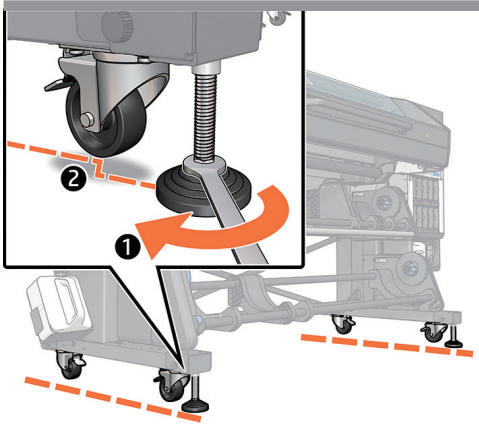

Ensure that the printer is standing on the front feet and not on the front wheels.

Note: The wheels should just touch the ground.

49



Now follow the start up instructions displayed in the front panel.

50



The installer is fully responsible of installing the RIP software and train the customer about how to operate with the printer, find and install new media profiles, how to print from the RIP SW. Use the Quick Guide for training topics, and leave it installed on the computer for future reference. The installer needs to send the End of Installation Report to register the printer, and confirm printer's warranty.

51



If the network requires a web proxy to access the Internet, ensure you have the proxy port and proxy address information.

If you setup a Manual IP Address, make sure to correctly enter the DNS and Gateway addresses. This information can be retrieved from a computer on the local network with internet connectivity, and should have been obtained during site preparation. See the Site Preparation Guide for instructions on how to obtain web proxy configuration information.

52



Important: Use the HP PrintOs Service Center Mobile Application to complete the End of Installation and register the printer in the PrintOS.

After the report is submitted, a confirmation message will be sent to you with the warranty validation information.

© Copyright 2021 HP Development Company, L.P.
The information contained herein is subject to change without notice. The only warranties for HP products and services are set forth in the express warranty statements accompanying such products and services. Nothing herein should be construed as constituting an additional warranty. HP shall not be liable for technical or editorial errors or omissions contained herein.