



**GRIMCO®**

• P: 800.542.9941 • F: 800.760.5575 • [www.grimco.com](http://www.grimco.com)

## **Epson SureColor S Series Pre Installation Checklist**



**Thank you for your equipment purchase! Please fill this out in its entirety. Once everything is completed, you will receive a phone call from our technicians to review. Once our technician has approved it, we will be more than happy to get you scheduled for your install!**

**If you have any questions please email [install@grimco.com](mailto:install@grimco.com) or call us at 877-283-5579.**

## CUSTOMER INFORMATION

Company name: \_\_\_\_\_

Contact name: \_\_\_\_\_

Company address: \_\_\_\_\_

City | State | Zip: \_\_\_\_\_

Phone: \_\_\_\_\_

Email: \_\_\_\_\_

Customer number: \_\_\_\_\_

## SOFTWARE INFORMATION

What RIP software will you be using? \_\_\_\_\_

If using existing software, please add key number: \_\_\_\_\_

What design software will you be using? \_\_\_\_\_

## TRAINING INFORMATION

How many users will operate this equipment? \_\_\_\_\_

How many users have past printing experience? \_\_\_\_\_

Do you have digital media to print on? \_\_\_\_\_

If you purchased a laminator, do you have laminate to work with? \_\_\_\_\_

If you purchased a flatbed, do you have substrates to print on? \_\_\_\_\_

NOTE – We limit training groups to six persons or less.

NOTE – Flatbeds require foam core to perform calibrations

## GRIMCO.COM

Do you know how to access Grimco's online Web Store? \_\_\_\_\_

Do you have a user's account set up? \_\_\_\_\_

If so, what is your user's name? \_\_\_\_\_

NOTE – If not, a Grimco technician will train you on accessing the site, getting an account set up, and provide a brief tutorial.

## COMPUTER AND SOFTWARE COMPATIBILITY

<i>Model</i>	<b>Bundled</b>	<b>Will Work</b>		
<i>HP L365</i>	<b>SAi Flexi Subscription (1 year)</b>	<b>Onyx 12.0 +</b>	<b>SAi Cloud</b>	<b>Caldera 11.0 +</b>
<i>HP L315/L335</i>	<b>SAi FlexiPrint HP Edition</b>	<b>Onyx 12.0 +</b>	<b>SAi Cloud</b>	<b>Caldera 11.0 +</b>
<i>HP L315/L335PrintCut</i>	<b>SAi HP FlexiPrint and Cut</b>	<b>Onyx 12.0 +</b>	<b>SAi Cloud</b>	<b>Caldera 11.0 +</b>
<i>HP L560/L570</i>	<b>N/A</b>	<b>Onyx 12.5 +</b>	<b>SAi Cloud</b>	<b>Caldera 10.2 +</b>
<i>HP FB550/FB750</i>	<b>N/A</b>	<b>Onyx 11.1.2 +</b>	<b>SAi Cloud</b>	<b>Caldera 10.0 +</b>
<i>HP R Series</i>	<b>N/A</b>	<b>Onyx 12.1 +</b>	<b>N/A</b>	<b>Caldera 12.0 +</b>
<i>HP 1500 Series</i>	<b>N/A</b>	<b>Onyx 12.1 +</b>	<b>N/A</b>	<b>Caldera 12.0 +</b>

<i>Model</i>	<b>Bundled</b>	<b>Will Work</b>		
<i>Epson F6200/F7200/F9200</i>	<b>Wasatch</b>	<b>Onyx 11.1 +</b>	<b>SAi Cloud</b>	<b>Caldera 10.2 +</b>
<i>Epson S40600/S60600/S80600</i>	<b>Onyx Gama Print</b>	<b>Onyx 11.1.2 +</b>	<b>SAi Cloud</b>	<b>Caldera 10.2 +</b>
<i>Epson F2100</i>	<b>Epson Garment Creator</b>	<b>Onyx 12.0 +</b>	<b>SAi Cloud</b>	<b>N/A</b>
<i>Epson P10000/P20000</i>	<b>N/A</b>	<b>Onyx 12.0 +</b>	<b>SAi Cloud</b>	<b>Caldera 10.2 +</b>

### ONYX COMPUTER SPECIFICATIONS

- Intel Core i7 or equivalent
- Supported 64-bit Operating Systems:
  - o Windows 7 Professional, Enterprise, Ultimate
  - o Windows 8.1 Professional and Enterprise
  - o Windows 10 Professional and Enterprise
- 250 GB drive or higher for Operating System
- Minimum 4 GB RAM
- USB and Network connections

NOTE – Windows Home Edition is NOT supported

### SAI FLEXI COMPUTER SPECIFICATIONS

- Intel Core i7 or equivalent
- Supported 64-bit Operating Systems:
  - o Windows Vista
  - o Windows 7 Professional, Enterprise, Ultimate
  - o Windows 8.1 Professional and Enterprise
  - o Windows 10 Professional and Enterprise
- 250 GB drive or higher for Operating System
- Minimum 4 GB RAM
- USB and Network connections

NOTE – Windows Home Edition is NOT supported

NOTE – Internet access is required for this install

### CALDERA COMPUTER SPECIFICATIONS

- Intel Core i3, i5, i7 based Mac mini, iMac or Mac Pro
  - Operating System 10.9 or higher
    - Minimum 4 GB RAM
- 250 GB drive or higher or Operating System
  - USB and Network connections

NOTE – MacBook Air, MacBook and MacBook Pro are NOT supported



## Epson SureColor S40600/S60600/S80800 Series

### Site Preparation Checklist

The estimated setup time for the Epson SureColor S Series printer is 1-2 hours. Make sure you have four or more people available to help the technician lift and guide the printer onto its stand.

#### SPACE REQUIREMENTS

The printer, stand, and media support system come on a pallet that weighs roughly 635 lbs. Make sure you can move the equipment from your receiving area to the printer's final location. For example, make sure it will fit inside an elevator, through doorways, and around corners. Keep the printer as horizontal as possible. The shipping dimensions are shown below:

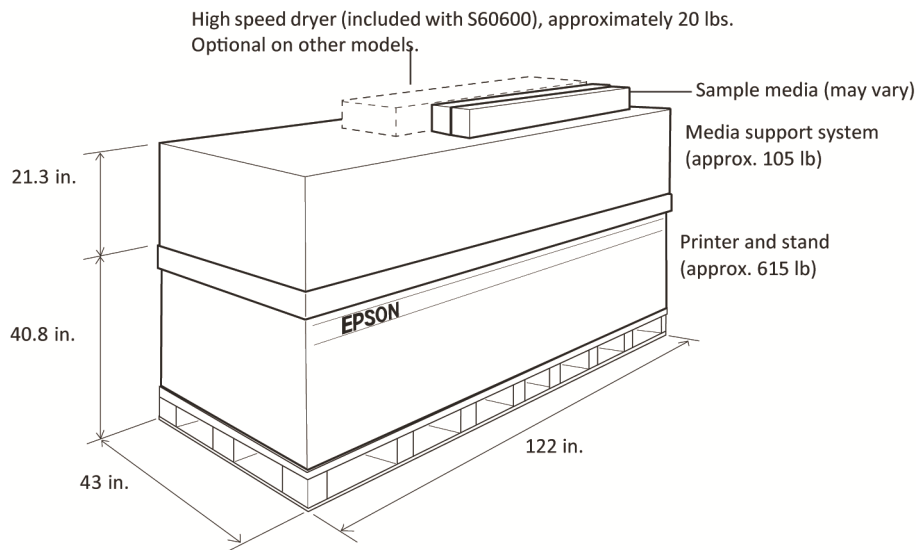

**NOTE – Size may vary slightly depending on the options and configurations.**

The amount of space required to use the printer is shown below, however, you will need a larger space to assemble it. Clear a large floor space before unpacking. Additional space is required when you use the carrying bars to place the printer on the stand. Also, be sure to leave enough space behind the printer to load media.

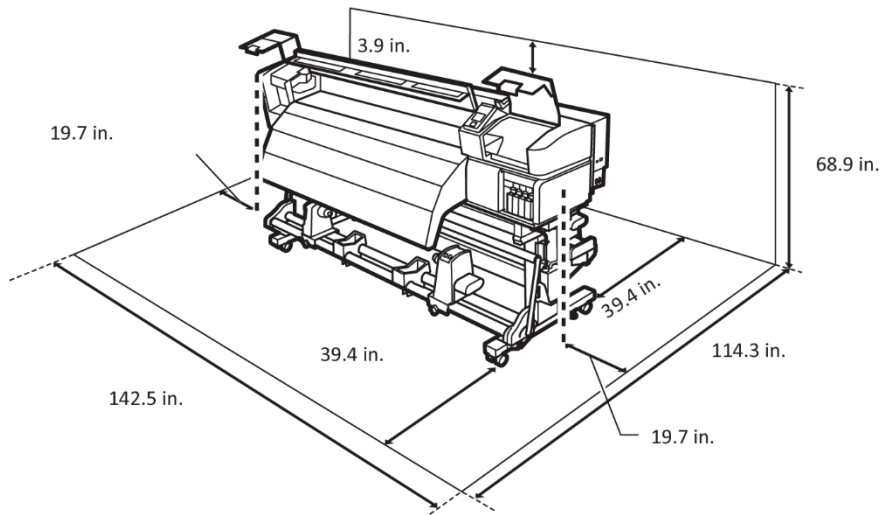

### ENVIRONMENTAL REQUIREMENTS

The Epson SureColor series printers should be installed in a location with typical air conditioning or air ventilation system. Avoid placing a printer near a vent that would blow directly at it. Area should be clear of dust and debris as that will affect internal functions of the machine.

	Operation	Storage
<b>Temperature</b>	<b>68-85°F</b>	<b>15-90°F</b>
<b>Humidity (without condensation)</b>	<b>40-60% RH</b>	<b>5-85% RH</b>

### ELECTRICAL REQUIREMENTS

You will need two electrical outlets to plug in the printer and the media support system. The printer requires 20A of power. These outlets are similar to the regular, small appliance outlets in your home.

<b>Specifications</b>	<b>Description</b>
<b>Voltage</b>	<b>110V</b>
<b>Frequency</b>	<b>50-60 Hz</b>
<b>Current</b>	<b>10A (10A x 2)</b>

**NOTE – The Epson SureColor S60600 requires an additional power outlet to operate the additional drying unit.**

**SITE PREPARATION INFORMATION**

1. After reviewing the crate dimensions, I will need to uncrate the printer and set it on its stand to be able to get it to its final location. Y/N: \_\_\_\_\_
2. I am able to provide a means to remove the printer from the delivery truck. Y/N: \_\_\_\_\_
3. I have either one of the following:  
Forklift \_\_\_\_\_ Pallet Jack \_\_\_\_\_ Neither \_\_\_\_\_
4. I require outside help to unload the equipment and get it into my building. Y/N: \_\_\_\_\_
5. Are there obstacles to getting the printer from the receiving area to the final location?  
Y/N: \_\_\_\_\_
6. I am able to provide four people to help lift and guide the printer onto its stand. Y/N: \_\_\_\_\_
7. I have adequate space to setup the printer. Y/N: \_\_\_\_\_
8. I can provide an Ethernet or USB cable at the time of install, as one is not provided with the printer.  
Please specify. Y/N: \_\_\_\_\_

**Customer is responsible for all networking requirements; you must complete the following tasks:**

- Have a Gigabit Ethernet network ready for the day of installation. Y/N: \_\_\_\_\_
- Provide a CAT -6 LAN Cable to connect the printer to your LAN and RIP station. Y/N: \_\_\_\_\_
- Provide a Gigabit Ethernet switch.

**To get the full features for your printer, it should be connected to the Internet.**

**NOTE – Can be run off Internet with USB, not recommended.**

9. I confirm I will have no live jobs with pressing due dates during the time of my install Y/N: \_\_\_\_\_

**INK AND MEDIA**

1. I have purchased, received, and verified my ink cartridges are the proper configuration for the Epson SureColor I purchased Y/N: \_\_\_\_\_
2. I have received the free roll of media to be used in the alignments and testing during my installation.  
Y/N: \_\_\_\_\_
3. After looking at the computer compatibility sheet, I am able to provide a computer that meets the requirements for the software I am using by the date of my install. Y/N: \_\_\_\_\_

**I hereby declare that the details above are true and correct to the best of my knowledge and belief, and I will inform you of any changes therein, immediately. In case any of the above information is found to be false or untrue, I am aware it will result in delays of my installation.**

**Signature:** \_\_\_\_\_

**Date:** \_\_\_\_\_